

Victoria Horner · Andrew Whiten

Causal knowledge and imitation/emulation switching in chimpanzees (*Pan troglodytes*) and children (*Homo sapiens*)

Received: 17 March 2003 / Revised: 18 August 2004 / Accepted: 20 August 2004 / Published online: 11 November 2004
© Springer-Verlag 2005

Abstract This study explored whether the tendency of chimpanzees and children to use emulation or imitation to solve a tool-using task was a response to the availability of causal information. Young wild-born chimpanzees from an African sanctuary and 3- to 4-year-old children observed a human demonstrator use a tool to retrieve a reward from a puzzle-box. The demonstration involved both causally relevant and irrelevant actions, and the box was presented in each of two conditions: opaque and clear. In the opaque condition, causal information about the effect of the tool inside the box was not available, and hence it was impossible to differentiate between the relevant and irrelevant parts of the demonstration. However, in the clear condition causal information was available, and subjects could potentially determine which actions were necessary. When chimpanzees were presented with the opaque box, they reproduced both the relevant and irrelevant actions, thus imitating the overall structure of the task. When the box was presented in the clear condition they instead ignored the irrelevant actions in favour of a more efficient, emulative technique. These results suggest that emulation is the favoured strategy of chimpanzees when sufficient causal information is available. However, if such information is not available, chimpanzees are prone to employ a more comprehensive copy of an observed action. In contrast to the chimpanzees, children employed imitation to solve the task in both conditions, at the expense of efficiency. We suggest that the difference in performance of chimpanzees and children may be due to a greater susceptibility of children to cultural conventions, perhaps combined with a differential focus on the results, actions and goals of the demonstrator.

Keywords Chimpanzees · Children · Imitation · Emulation · Causality

Introduction

Many of the tool-using activities of both chimpanzees and children involve a complex mixture of interconnected causal relationships between a tool and a reward, and much of this tool use is thought to be acquired, at least in part, by social learning (Boesch and Tomasello 1998). However, despite the considerable research effort that has been focused on both causal understanding and social learning, few studies have directly addressed the potential interaction between these fields of research. It seems likely that the way in which an individual learns to use a tool through observation will be significantly influenced by its interpretation of the causal relationships that are involved. This paper will examine whether knowledge of causal relationships influences the way in which chimpanzees and children learn by observation.

Social learning has been investigated for over a century, during which time numerous different learning strategies have been identified and categorised, each varying with respect to the match between the actions of the demonstrator and observer (Whiten and Ham 1992). However, within the recent comparative primate literature two particular strategies have received considerable attention; emulation and imitation.

Emulation refers to a process whereby through watching a model, an observer learns about the results of actions, rather than details of the behaviour involved (Tomasello et al. 1987). For example, an individual may learn to use a tool by observing the effect of the tool in gaining a reward, and seek to reproduce this outcome using their own efficacious actions (Tomasello 1998).

This possibility was first highlighted by Tomasello et al. (1987) to differentiate a level of social learning more sophisticated than enhancement (in which attention is merely drawn to an object or location), but without the behavioural fidelity required for imitation. This learning mechanism

V. Horner (✉) · A. Whiten
Centre for Social Learning and Cognitive Evolution, School of Psychology, University of St Andrews,
St Andrews, KY16 9JU, UK
e-mail: vkh1@st-andrews.ac.uk
Tel.: +44-1334-462073
Fax: +44-1334-463042

was later named “emulation” (Tomasello 1990). As a term, emulation has been used divergently to describe a wide range of social learning processes. Initially referring to copying the results of actions (Tomasello 1990), it was later used to describe copying the affordances and causal relationships of a task (Tomasello 1996; Want and Harris 2001, 2002), as well as being sub-divided into several different categories (Byrne 1998; Custance et al. 1999). For the purposes of this paper, we shall use emulation more generally to describe social learning in which the observer attempts to reproduce the results of a model’s actions, rather than the details of the observed behaviour.

By contrast, imitation occurs when an observer learns some specific aspect(s) of the intrinsic form of an act from the observation of a model (Whiten and Ham 1992). An observer would therefore produce a recognisable (if not accurate) copy of the original behaviour required to bring about the same result as the model. For example, an individual may learn to use a tool by observing the effect of the tool in gaining a reward, and then seek to reproduce the same effect by using a similar behaviour pattern to that which they had witnessed. Imitation is distinct from other forms of social learning insofar as the behavioural technique of the model is attended to. Thus, we contrast imitation with emulation in that during imitative learning the observer reproduces a more complete copy of the model’s behaviour. Such a copy may include both the method and results achieved by the model.

A number of studies have found evidence for imitation in chimpanzees, many of which have involved the manipulation of objects, such as the “artificial fruit” paradigm (Whiten et al. 1996; Whiten 1998, 2002), or the reproduction of arbitrary manual and facial gestures (Custance et al. 1995). In contrast, studies that have involved tool-use paradigms have often failed to show imitation, finding evidence instead for emulation (Tomasello et al. 1987; Nagell et al. 1993; Call and Tomasello 1994; Myowa-Yamakoshi and Matsuzawa 2000). Rather than suggest that the use of imitation or emulation is related to the task domain per se, we suggest that another variable may be involved in mediating which social learning strategy chimpanzees tend to employ.

From the definitions of imitation and emulation above, it follows that the perception of information about causal relationships should be important for emulation, yet may be less critical for imitation (Want and Harris 2001). During emulation an observer must piece together the causal links within a task in order to achieve the same result using a different method. In contrast, imitation requires only that the observer reproduce the actions of the model with sufficient fidelity to recreate the desired outcome, without having to fully appreciate the causal relationships involved.

Traditionally, imitation has been viewed as the apex of social learning, producing the highest fidelity match to the actions of the model (Galef 1992; Heyes 1993; Tomasello et al. 1993a,b). However, this does not mean that imitation will always be the optimal social learning strategy. When describing emulation, Tomasello et al. noted that

“the most efficient strategy might be to simply observe the relation between the tool and the goal and then experiment with the specifics on one’s own”. (1987, p 182), thus allowing an individual to generalise socially learned behaviours to different environmental conditions and problems (Tomasello et al. 1987; Visalberghi 1994; Want and Harris 2001, 2002). Emulation may therefore be a more appropriate strategy than imitation in certain situations. It may be that when critical causal relationships are apparent to the observer, emulation is preferred due to the flexibility and potential for generalisation that this strategy affords. In contrast, imitation may be more efficient when such causal relationships are not perceivable or are difficult to infer, and thus emulation is not possible.

This interpretation of strategy selection is consistent with the pattern of evidence for imitation and emulation found in the ape social learning literature. Object manipulation studies such as the artificial fruit may have found evidence for imitation because the causal features of the task (the helpful effects of removing locking bolts, for example) may be difficult to perceive. The most appropriate way to remove the defences of an artificial fruit may therefore be to attend to, and reproduce the actions of the demonstrator, in accord with imitation. Similarly, strong evidence for imitation may be found in studies that involve the reproduction of gestures because the gestures themselves have no causal or environmental aspect. In contrast, in tool-use paradigms such as the raking study by Tomasello et al. (1987), the causal effect of the tool on the reward could be constantly monitored, thus enabling subjects to employ emulation. In this paper we set out to empirically test whether the tendency of an individual to use emulation or imitation is influenced by their access to information about causal relationships. However, first we must briefly determine whether the causal knowledge of chimpanzees and children is sufficient to warrant such an involvement in social learning.

Chimpanzee causal knowledge has mainly been investigated in the context of tool use. Wild chimpanzees use tools with highly specialised functions, selecting and modifying raw materials on the basis of shape, strength and flexibility (Goodall 1986; Tomasello et al. 1987; Boesch and Boesch 1990; Suzuki et al. 1995). Chimpanzees have been reported to modify the same tool in up to three different ways, often without using trial and error (Sugiyama and Koman 1979; Sugiyama 1985; Boesch and Boesch 1990). Furthermore, they have been found to use tool sets comprised of up to four different manufactured tools (Brewer and McGrew 1990; Suzuki et al. 1995) and to use tools in combination (Sugiyama 1997).

This ability to appropriately modify and use tools has been replicated under experimental conditions with captive chimpanzees (Limongelli et al. 1995; Visalberghi et al. 1995). However, such controlled studies have often indicated that the causal knowledge that underlies these abilities is based on identifying observable regularities in the environment that are used to form useful procedural rules (Köhler 1927; Visalberghi and Tomasello 1998; Povinelli 2000; Reaux and Povinelli

2000). In other words, chimpanzees are able to perform seemingly complex tool-use behaviours because they form useful rules about how the tools can be used, rather than a conceptual understanding of the causal principles involved.

Studies of human children suggest that they may have a more conceptual understanding of causality than chimpanzees, seeking causal explanations for observed effects, and that such a conceptual interpretation of causality may be unique to humans (Tomasello 1998; Povinelli 2000; Povinelli and Dunphy-Lelii 2001). Nevertheless, the ability of chimpanzees to recognise reliable connections between a cause and an effect, and form useful rules of action, appears to be all that is required to identify the causally relevant parts of an observed behaviour. Therefore, even conservative interpretations of the literature suggest that the causal knowledge of both chimpanzees and children is likely sufficient to influence social learning.

If, as we suggest, causal information is involved in determining which social learning strategy an observer employs, it would be expected that an individual could be encouraged to switch between emulation and imitation by varying the availability of causal information. In the present study, young chimpanzees and 3- to 4-year-old children observed a demonstration of a tool-using task that contained both relevant and irrelevant actions. We predicted that when appropriate causal information about the task was available (by presenting the task in a transparent condition), participants would be able to differentiate between the relevant and irrelevant parts of a demonstration. Chimpanzees, and possibly children, would therefore selectively exclude the irrelevant actions so as to develop a different and more efficient method, in accord with emulation. However, if the task was presented in an opaque condition, so that access to causal information was restricted, we predicted that participants would perform a greater proportion of the demonstrated irrelevant actions, consistent with imitation.

Experiment 1: chimpanzees



Study site

Data collection took place at Ngamba Island Chimpanzee Sanctuary, Uganda. At the time of the study, the island was home to 34 wild-born chimpanzees rescued from Uganda and surrounding countries mainly as victims of the bushmeat trade. Ngamba is situated in Lake Victoria, 23 km from the southern coast of the mainland, and is covered by 100 acres of tropical rain forest. The sanctuary incorporates the forest as well as a large holding facility, which consists of six rooms with interconnecting raceways.

Participants and rearing history

Participants were 12 chimpanzees, ranging in age from 2 to 6 years old, of both sexes (see Table 1). Unlike many exper-

Table 1 Experimental design for groups A–D. Subjects were matched as far as possible for age and sex. Groups A and B worked with the opaque box first (O1–O3) and then the clear box (C1–C3). Groups C and D experienced the reverse order. Groups A and C observed demonstrations of method 1, and groups B and D observed demonstrations of method 2

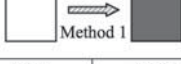
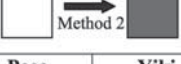
A				
	Mukisa Female 3yrs	Baluku Male 3yrs	Kalema Male 6yrs	Mean Age 4yrs
B				
	Yoyo Female 3yrs	Indi Male 3yrs	Umutama Male 6yrs	Mean Age 4yrs
C				
	Bili Female 4yrs	Asega Male 3yrs	Umugezi Male 5yrs	Mean Age 4yrs
D				
	Pasa Female 2yrs	Yiki Male 3yrs	Nkumwa Female 6yrs	Mean Age 3.67yrs

imental studies, the chimpanzees in this experiment were wild-born individuals who had daily access to a species-typical African forest habitat. The majority of these chimpanzees arrived at the sanctuary between 1999 and 2000, and hence, despite differences in age, had been at Ngamba for approximately the same length of time. They spent a large portion of each day in a holding facility, whilst adult chimpanzees at the sanctuary were in the forest. When in the holding facility, the young chimpanzees received considerable behavioural enrichment in the form of simulated foraging tasks, and novel objects. Twice a day they were allowed access to the forest with human caregivers and adult female conspecifics. There, they were exposed to a natural setting where they could undertake more species-typical behaviours. The rearing history of the subjects can therefore be regarded as a mixture representing both captive and wild environments.

Apparatus

We used two structurally identical 20-cm³ polycarbonate boxes, one clear, the other opaque (see Fig. 1). On the top of each box was a square hole 3 cm × 3 cm, covered by a “bolt-defence”, which could be removed to expose a hole. On the front face of the box was a square hole 2 cm × 2 cm, connected to a sloping opaque tube housed inside the box. This hole was covered by a door-defence, described in more detail below. A food reward was placed at the bottom of the opaque tube, and could be retrieved by opening the front door, inserting an aluminium tool (22 cm × 1 cm) into the front hole and pulling out the reward. Actions directed to the top of the box were not necessary to retrieve the reward. Insertion of the tool in the top hole resulted only in hitting a polycarbonate barrier that prevented physical contact between the tool and the food tube (see Fig. 1).

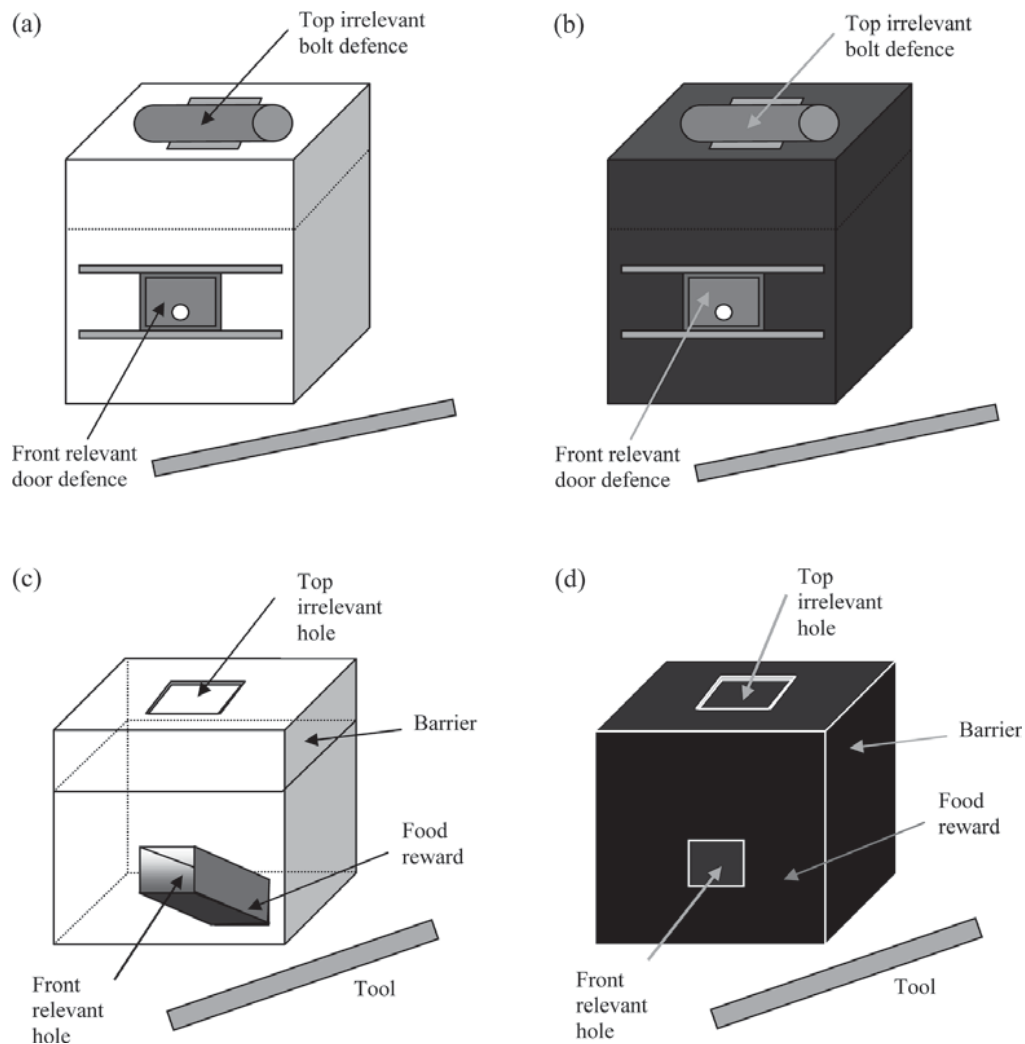

Fig. 1 **a, b** External view of the clear and opaque boxes. **c, d** Cut-away diagram of the clear and opaque boxes. Note that in both cases the food tube housing the reward is opaque so that the location of the reward cannot be directly seen

Manipulation of the box could therefore be divided into irrelevant actions directed at the top of the box, and relevant actions directed at the front.

Two-action design

The apparatus incorporated an additional “two-action” design to further investigate the importance of imitation (Dawson and Foss 1965). Both the bolt and door defences could be removed in one of two ways. The bolt could either be pushed out from the right, or dragged out from the left by inserting the tool into a hole at the end of the bolt to reveal the hole beneath. Before the bolt was removed, it was hit three times on the opposite end from which it would be pushed or dragged, thus controlling for stimulus enhancement by touching both ends in all cases. The door could either be manually lifted or slid out of the way to reveal the hole beneath. Subjects were shown one of two methods of defence removal; method 1—push bolt, lift door, or method 2—drag bolt, slide door (see Fig. 2). If subjects

performed the observed method significantly more than the alternative, this would be a strong indication of imitation (Whiten et al. 1996).

Procedure

Subjects observed a human demonstrator use the tool to retrieve a food reward from one of the boxes. The demonstration involved two parts; (1) irrelevant actions—removing the top bolt and inserting the tool in the top hole and (2) relevant actions—opening the door and inserting the tool in the front hole to retrieve the reward. As noted above, only the relevant actions to the front were required to retrieve the reward.

The apparatus was presented in two conditions, opaque and clear (see Fig. 1). In the opaque condition, causal information was unavailable: subjects could not see the location of the food tube, or the effect of the tool within the apparatus. It was predicted that when the causal information was restricted in this way, subjects would

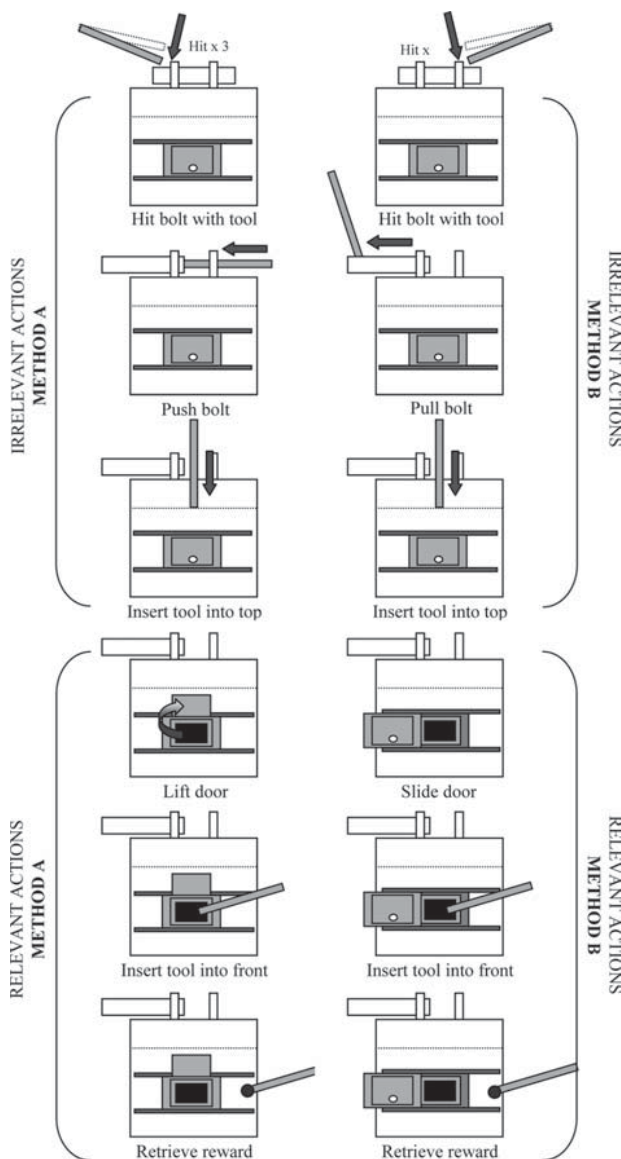

Fig. 2 Schematic representations of two-action defence removal. Method 1: hit bolt on left, push out bolt from right, lift door. Method 2: hit bolt on right, drag out bolt from left, slide door. The bolt and door can be removed in either way to reveal the holes beneath

selectively include both irrelevant and relevant actions in their own later efforts, consistent with imitation.

In the clear condition causal information was available, as the effect of the tool inside the box could be viewed. It was therefore possible to perceive that actions in the top of the box had no causal link with the reward. It was predicted that here, subjects would be inclined to develop an alternative, more efficient strategy by selectively excluding the irrelevant top actions, consistent with emulation.

In both the opaque and clear conditions the food tube was painted black, so subjects could not see the location of the reward. In addition, the reward was wrapped in black plastic ensuring that even if a subject opened the front

and looked down the dark tube, they could not see or smell the reward at the bottom.

Subjects were tested individually in a large research room (4 m × 8 m × 4 m high) within the holding facility. Prior to each trial the experimenter entered the room and played with or groomed the subject for approximately 5 min. Testing began as soon as the subject was judged to be comfortable. The experimenter then moved to the apparatus, which was bolted to a bench. The chimpanzee typically sat close beside, or on the lap of the experimenter. In this respect the methodology was naturalistic in that the subject observed the demonstration from the same perspective as it was performed, and the proximity of the experimenter and subject was analogous to a mother–infant pair.

Following Whiten (1998), each subject received three consecutive demonstrations before their first trial. They then received a further two demonstrations and two trials:

Demo > Demo > Demo > Trial 1

> Demo > Trial 2 > Demo > Trial 3

Each trial lasted 5 min, or until the subject retrieved the reward, whichever occurred first. A second experimenter then re-baited the apparatus while the chimpanzee was distracted. To ensure that the subject did not observe the baiting process, they were taken to the other side of the room and engaged in a play or grooming session. After trial 3, subjects were returned to the holding room for 20–30 min before the testing was repeated in the alternative condition (opaque or clear; see Fig. 3). All demonstrations and trials were recorded by the second experimenter on a hand-held video camera.

Subjects were divided into four groups (see Table 1). Groups A and B received three trials first with the opaque box (O1–O3) and then three trials with the clear box (C1–C3), to determine whether different social learning strategies were employed in each condition. To ensure that any change in strategy between opaque and clear could not be due to presentation order, subjects from groups C and D interacted with the clear apparatus first (C1–C3), then the opaque apparatus (O1–O3). In order to investigate the role of imitation further, groups A and C observed method 1 of the two-action alternatives, and groups B and D observed method 2. The experimental design is summarised in Table 1.

Coding and data analysis

The video-taped behaviour of each subject was analysed by recording each occurrence of the following categories:

HBT	Hit bolt with tool (left end, middle, right end)
HBH	Hit bolt with hand (left end, middle, right end)
PB	Push bolt from right (method 1)
DB	Drag bolt from left (method 2)

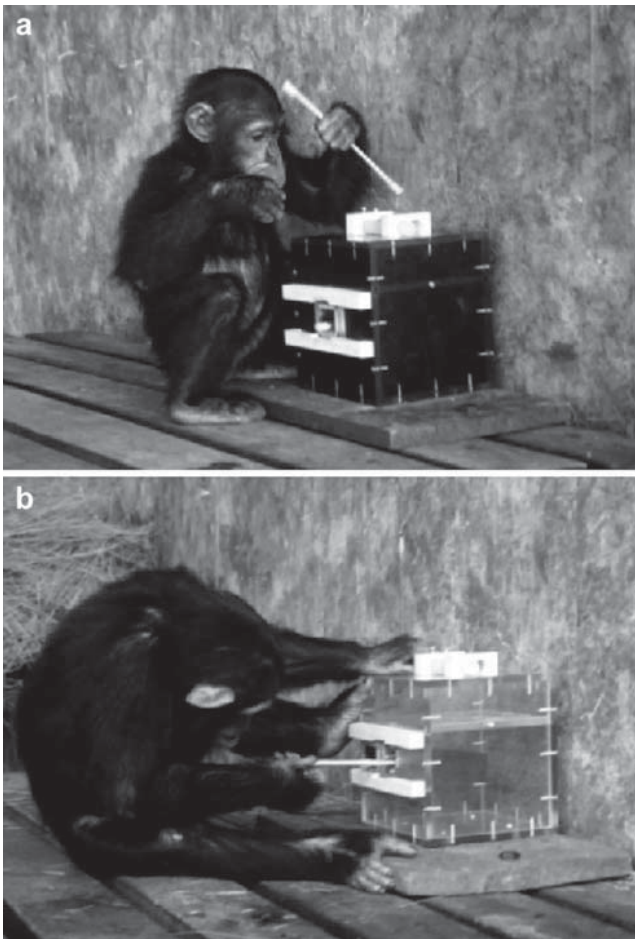

Fig. 3 **a** Subject inserts tool into the top irrelevant hole of the opaque apparatus, **b** subject inserts tool into front relevant hole of the clear apparatus to retrieve the food reward

ITT	Insert tool in top, “irrelevant” hole
H	Hit barrier (number of times recorded)
LD	Lift door (method 1)
SD	Slide door (method 2)
ITF	Insert tool in front, “relevant” hole
✓	Retrieve food reward

The proportion of irrelevant actions in each condition was determined by calculating the number of tool insertions into the top irrelevant hole (ITT), as a percentage of total tool insertions (ITT+ITF). This measure was used because tool insertions could be clearly identified and quantified. The remaining codes were used to determine each subject’s tendency to reproduce the two-action method that they had observed.

Results

Ten random trials, representing 15% of the data, were recorded by an independent observer, naive to the hypotheses of the experiment. Inter-observer reliability was high for

both the number of irrelevant tool insertions (ITT: Cronbach’s $\alpha=0.96$) and for the number of relevant tool insertions (ITF: Cronbach’s $\alpha=0.99$). With the exception of Yiki, Mukisa and Indi, all subjects were successful in retrieving the reward. These three subjects had difficulty retrieving the reward only because they mashed it into the bottom of the tube with the tool, and were not able to lever it out. They were not unsuccessful because they used a different overall technique. Success rate was not analysed, because we were interested in the method used to reach the reward following observation. Medians are quoted as a measure of the central tendency since frequency data have been reported. All statistics are non-parametric; Mann–Whitney U tests for unmatched samples have been used to compare the behaviour of subjects from different experimental groups, and Wilcoxon tests for matched pairs have been used to compare the behaviour of the same subjects under the two different experimental conditions. All statistics are two-tailed.

No effect of two-action method on the reproduction of irrelevant actions

There was no significant difference in the proportion of irrelevant actions (ITT) performed by subjects in groups A and B, who interacted with the opaque box first, yet observed different two-action alternatives (median A=21.25, median B=35.06; $Z=-0.66$, $n_1=3$, $n_2=3$, $P=0.7$). Similarly, there was no significant difference in the production of irrelevant actions (ITT) by subjects from groups C and D, who interacted firstly with the clear box, but observed different two-action alternatives (median C=0, median D=15.48; $Z=-0.69$, $n_1=3$, $n_2=3$, $P=0.7$). Therefore the proportion of irrelevant actions was not influenced by the two-action method that the subjects observed. Two collapsed groups, A/B (opaque > clear) and C/D (clear > opaque) have therefore been used to investigate the effect of the opaque and clear condition of the apparatus on the reproduction of irrelevant actions.

Reproduction of relevant and irrelevant actions

Subjects from group A/B performed a significantly greater proportion of irrelevant actions with the opaque apparatus than with the clear apparatus (median A/B opaque = 59.05, median A/B clear = 6.25; $Z=-2.20$, n -ties = 6, $P=0.03$; see Fig. 4). Subjects from group C/D, who were presented with the clear box first, did not perform significantly differently from group A/B with the clear box (median A/B clear = 6.25, median C/D clear = 0; $Z=-0.36$, $n_1=6$, $n_2=6$, $P=0.72$). However, there was a significant difference in the performance of group A/B with the opaque box when compared to group C/D with the clear box (median A/B opaque = 59.05, median C/D

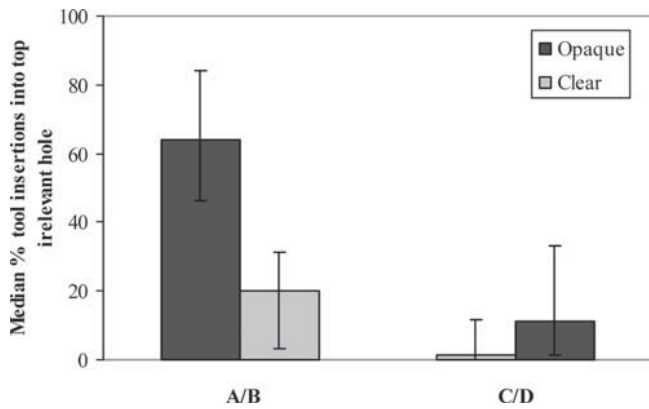

Fig. 4 The median percentage of tool insertions into the top, irrelevant hole by subjects from groups A/B and C/D in both the opaque and clear conditions. *Error bars* represent the inter-quartile range

clear = 0; $Z = -2.61$, $n_1 = 6$, $n_2 = 6$, $P = 0.01$). This suggests that the change in behaviour of group A/B from the opaque to the clear apparatus was not the result of order of presentation.

When subjects from group C/D then transferred from the clear box to the opaque box, although there was a slight increase in the reproduction of irrelevant actions, this was not significant (median C/D clear = 0, median C/D opaque = 8.34; $Z = -1.60$, n -ties = 3, $P = 0.11$). The data suggest that subjects generally continued to ignore the irrelevant top actions with the opaque box, indicating that they were able to generalise their previous causal knowledge about the apparatus to the new experimental condition (compare A/B and C/D in Fig. 4).

Reproduction of two-action method of door removal

Subjects from groups A and C (A/C) who observed method 1 to remove the door-defence (lift door), employed this technique significantly more than subjects from groups B and D (B/D) who observed method 2—slide door (median percentage lift door A/C=96.36, median B/D=33.33; $Z = -2.01$, $n_1 = 6$, $n_2 = 6$, $P = 0.04$; see Fig. 5). This effect was confirmed by an independent coder who was able to correctly identify the method of door removal observed by six randomly selected subjects (6/6, two-choice binomial, $p = 0.03$). Similarly, subjects from group B/D, who observed method 2 (slide door), employed this technique significantly more than subjects in group A/C who observed method 1—lift door (median percentage slide door B/D=61.34, median A/C=8.74; $Z = -2.01$, $n_1 = 6$, $n_2 = 6$, $P = 0.04$).

In order to assess whether the order of presentation of the opaque and clear boxes affected subjects' tendency to reproduce the demonstrated method of door removal, a mean percentage of "correct" door removal was calculated for each group. For group A/C correct door removal was method 1 (lift door), and for group B/D correct door removal was method 2 (slide door). There was no significant difference in performance between group A/B and

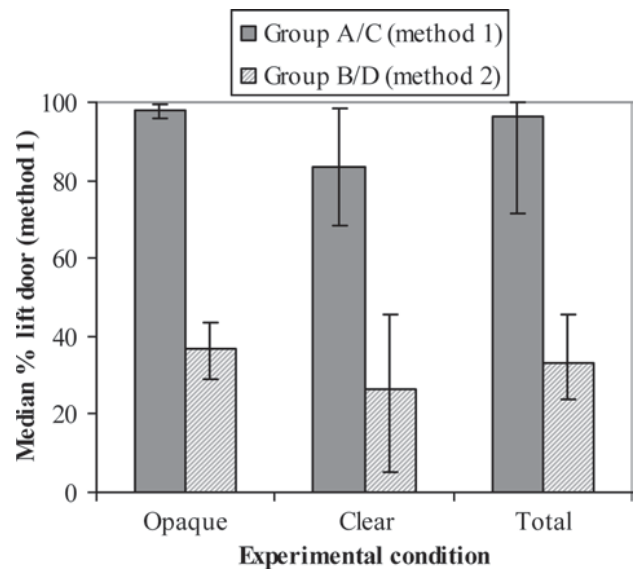

Fig. 5 Median percentage of lift door (method 1) used by group A/C who saw method 1, and group B/D who saw method 2. *Error bars* represent the inter-quartile range

group C/D on the opaque box (median A/B=98.05, median C/D=83.36; $Z = -0.08$, $n_1 = 6$, $n_2 = 6$, $P = 0.94$), so order of presentation had no significant effect on subjects' tendency to reproduce the demonstrated actions. The same was true in a comparison for the clear box (median A/B=63.42, median C/D=73.35; $Z = -0.65$, $n_1 = 6$, $n_2 = 6$, $P = 0.59$).

Reproduction of two-action method of bolt removal

All subjects performed a large number of actions to the bolt using both the tool and their hands. However, the majority of subjects discovered that the tool could be inserted into the top irrelevant hole through a small gap behind the bolt, and it was therefore not necessary to remove the bolt in order to insert the tool. Nevertheless, five subjects were observed to remove the bolt-defence, four from group A/C and one from group B/D. However, they did not consistently use the observed method, and unfortunately there were insufficient data to perform statistical analysis. However, a detailed assessment revealed that subjects performed actions to the middle area of the bolt, which was not part of the demonstrated method, as often as they performed actions to either end ($\chi^2 = 0.63$, $df = 2$, $P = 0.73$). In addition, there was no significant difference in the order in which each part of the bolt was contacted ($\chi^2 = 0.09$, $df = 2$, $P = 0.96$). These findings suggest the actions were exploratory, and not influenced by the two-action demonstration.

Discussion of experiment 1

Subjects from group A/B, who interacted first with the opaque box, performed significantly more irrelevant actions in the opaque condition than in the clear condition

(see Fig. 4). In each condition, both the structure of the apparatus and the observed demonstrations were identical. The only difference between the two conditions was whether the box was clear or opaque, and hence the availability of causal information.

Non-social learning cannot explain these results, as the food tube in which the reward was located was opaque in both conditions, and the food wrapped in opaque plastic, so subjects could not see or smell the food directly. Hence food targeting cannot explain why subjects only reproduced relevant actions in the clear condition. Additionally, subjects' inclusion or exclusion of the irrelevant actions was present from trial 1. In each case there was no opportunity before the first trial to discover the causal features of the task by individual learning, and therefore the selective inclusion or exclusion of parts of the demonstration must be due to information that was gained by observation.

It is difficult to explain the selective inclusion of non-functional, irrelevant actions in the opaque condition in terms of emulation, where the observer attempts to recreate the results of the demonstrator's actions using a different method. The only result produced by the irrelevant actions was hitting the concealed barrier, which did not in itself result in a salient reward (i.e. the food reward). If subjects were attempting to reproduce this result for its own sake, we would expect them to continue to do so in the clear condition. However, the reproduction of irrelevant actions decreased significantly in the clear condition. The behaviour of subjects from group A/B in the opaque condition, where causal information was unavailable, is therefore most consistent with imitative learning of the overall structure of the task (Byrne and Russon 1998). Moreover, subjects significantly used the observed two-action method of door removal, indicating that matching of the model's behaviour occurred at this detailed level.

When the same subjects transferred to the clear box, there was a significant drop in the reproduction of irrelevant actions. This change in behaviour was not the result of prior exposure to the apparatus, as group C/D, who interacted first with the clear box, performed in a similar way (see Fig. 4). Again, the only difference between the two conditions was the availability of causal information. It is therefore likely that when exposed to the clear box, both groups A/B and C/D were able to utilise the available causal information to differentiate the irrelevant parts of the demonstration, and selectively exclude these actions in favour of a more efficient method. Hence, the performance of subjects from group A/B and C/D in the clear condition, where causal information was available, is most consistent with emulation.

When subjects from group C/D were then presented with the opaque box, they continued to selectively exclude the irrelevant actions, although the opportunity to monitor the causal role of the tool had been removed. This suggests that the chimpanzees may have been able to generalise the knowledge gained through previous experience to the new opaque condition.

Two-action design

The chimpanzees used the observed two-action method of door-defence removal significantly more than the alternative (Fig. 5). Since the method used to remove each defence was arbitrarily assigned to each subject, reproduction of the observed technique is viewed as an indicator of copying occurring at this more detailed level (Dawson and Foss 1965; Whiten et al. 1996). Only five subjects successfully removed the bolt, but did not consistently use the observed two-action method. The majority of subjects discovered that it was possible to insert the tool into the top hole through a small space behind the bolt, rendering the removal of the bolt redundant. It is therefore not surprising that subjects did not consistently attend to this feature of the demonstration. Indeed, this observation provides additional evidence that subjects were sensitive to the causal relevance of observed actions when such information was available.

Experiment 2: chimpanzee control test—knowledge of tool-reward contact

In experiment 1, one subsidiary hypothesis explaining the reduction in the reproduction of irrelevant actions in the clear condition is that the chimpanzees recognised that the tool could not make physical contact with the reward. However, experiment 1 did not directly show that such an appreciation existed. The following experiment was designed to determine whether there was evidence that subjects showed causal knowledge of the significance of tool-reward contact, tested in a different context.

Participants

Participants were the same 12 chimpanzees who participated in the previous experiment. This experiment was conducted 1 week after the completion of experiment 1.

Apparatus

The apparatus consisted of two identical rakes with wooden handles and metal raking-heads. Both rakes were 98 cm in length with a raking-head width of 25 cm.

Procedure

The rakes were placed on the ground, 1 m from the holding facility for 24 h prior to the start of the experiment. This allowed subjects to view the apparatus and reduce potential neophobic responses. During testing, the rakes were placed outside the research room with the handles protruding 10 cm through the bars into the room, so that subjects could pull the rakes toward them. The metal raking heads

were sufficiently heavy and angled so that the rakes could not be freely manipulated or easily lifted off the ground, encouraging the chimpanzees to only pull the rakes towards them. One rake was in physical contact with a food reward, or in a configuration that would make contact with the reward if the rake were pulled. The other rake did not make contact with the reward, or was positioned so that if pulled, the raking-head would not contact the reward. Hence, in each trial there was only one correct choice of rake. The ability of subjects to select the correct rake was therefore dependent on recognition that the tool must make physical contact with the reward in order to have a salient effect. Each subject received ten trials, each with a different choice of rake/reward configuration (see Fig. 6). The position of the food reward, and side of correct choice was randomised. The food reward was always placed on the inside of the rake handle, as it may have been hidden from the subject's line of sight if placed on the outside of the rake. The choice of configurations was therefore limited.

Data were collected concerning the first tool choice in each trial. Subjects were allowed to select one rake and pull it towards them. If the correct rake was selected first, the subject was allowed to pull in the reward. If the wrong rake was selected first, the subject was allowed to pull it in and fail. In both conditions, once one rake had been pulled, both rakes were removed and the trial was terminated. During each trial an experimenter was present in the research room with the subject. Trials began once the subject was comfortable, usually after a period of approximately 5 min of grooming and playing. During each trial the experimenter sat behind the subject exactly between the two rakes (see Fig. 7a). A second experimenter, outside the research room, was responsible for setting up the apparatus for each new trial. All trials were recorded on a tripod-mounted video camera outside the room.

Results

The correct tool was chosen significantly more than would be expected by chance (median percentage correct=80, median chance=50; $Z=-2.82$, n -ties = 10, $P=0.01$). Two subjects had a perfect score, and three subjects only made one error throughout the ten trials. There was no evidence of a learning effect across the ten trials. Indeed, it seems that the chimpanzees' performance worsened across the block of trials, possibly as a result of decreased motivation or food satiation (Spearman's $P=-0.78$, $n=10$, $P=0.008$). There was no relationship between the age of each subject and their performance (Spearman's $P=0.057$, $n=12$, $P=0.86$).

Discussion of experiment 2

The primary purpose of this experiment was to determine whether chimpanzees recognised that a tool must contact an object before it can effect it. The results indicate that

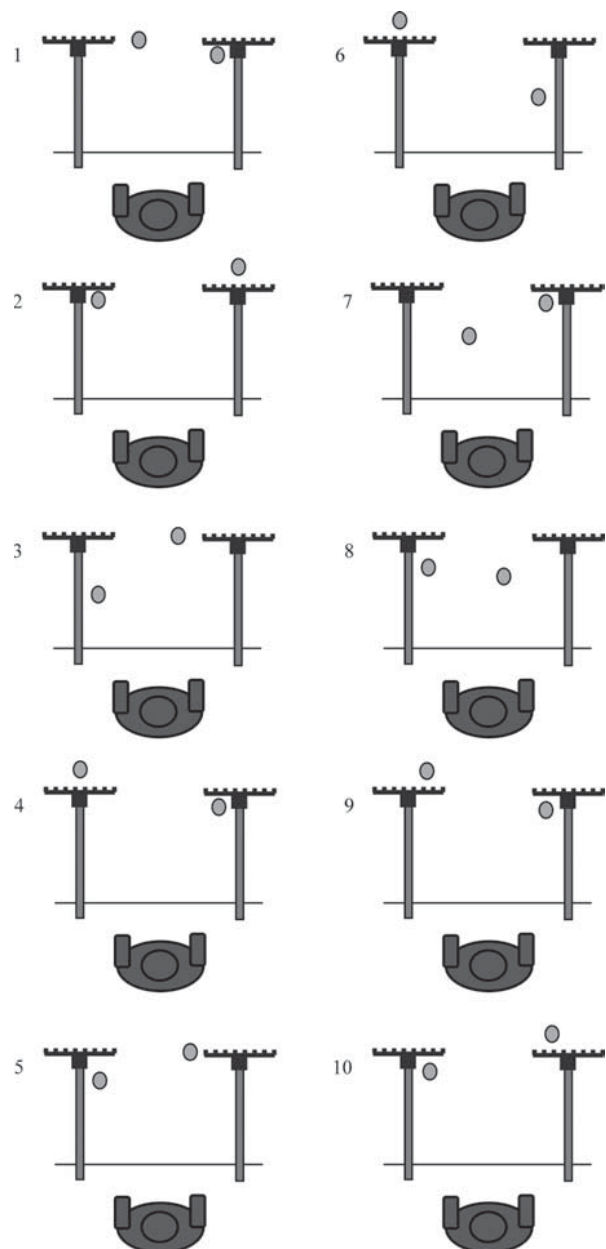

Fig. 6 Schematic diagram of tool/reward choices presented in experiment 2 (viewed from above)

as a group, the chimpanzees could select the tool that was in contact, or had the potential to make contact with the reward, significantly more than the incorrect alternative. Two subjects chose correctly on every trial and three subjects made only one error. The results are consistent with Köhler (1927) and Povinelli (2000), who reported that although chimpanzees found it difficult to discriminate between physically connected objects, and objects that were simply touching, they could correctly select tools that were in contact, or had the potential to make contact with a reward. The chimpanzees in the present study may have found this task relatively easy because they had prior knowledge about tool/reward contact gained from



Fig. 7 Subject selects the correct tool to retrieve the food reward

previous experience, but were clearly able to adapt this knowledge to the new situation. It therefore seems likely that the ability of subjects in experiment 1 to determine by observation that actions to the top of the clear box were irrelevant, was based on recognition that if the tool did not contact the reward, it could not bring about a salient effect.

Experiment 3: chimpanzee control test—knowledge of barriers

In experiment 1, a clear polycarbonate barrier prevented contact between the tool and the reward. Experiment 2 indicates that subjects had knowledge about the necessity of tool-reward contact. The following experiment was designed to determine whether subjects recognised that clear barriers would prevent contact between a tool and reward.

Participants

Participants were the same 12 chimpanzees who participated in the previous experiments. This experiment was conducted 1 week following the completion of experiment 2.

Apparatus

Two identical boxes were used to test subjects understanding of barriers. Each box was composed of a welded steel frame (36 cm³) with transparent Perspex panels on three of the four sides. The panels were scratched slightly so that they were visible, and a rake was placed in front of each box (see Fig. 8). The rakes were the same rakes used in experiment 2, but the handle and metal rake-head were shortened to make the tools lighter and easier to manipulate (rake length 60 cm, raking-head width 10 cm).



Fig. 8 Subject selecting the correct box

Procedure

The apparatus was left outside the holding facility for a period of 24 h prior to the start of the experiment, to allow subjects to become familiar with the apparatus, and reduce the potential for neophobic responses. The procedure for this experiment was very similar to experiment 2, in that subjects were presented with a choice of two configurations, only one of which could yield a reward. In this case, both boxes contained a visible piece of banana, but in one box access to the reward was prevented by a Perspex barrier. Subjects therefore had to select the rake in front of the correct box to retrieve the reward. Subjects were presented with eight pairs of choices. In some trials, one box was positioned with an open front and the other with a Perspex front, so that only one box could yield a reward. In other trials, both boxes had Perspex barriers, but one box had food located outside. The position of the reward relative to the box was randomised (see Fig. 9). Subjects were tested individually within the research room.

Data were collected concerning the first tool choice by each subject for every trial. If the correct rake was selected first, the subject was allowed to use it to retrieve the reward. If the wrong rake was selected first, the subject was allowed to use it to hit the barrier and fail. Both rakes were then removed and the trial was terminated.

In some cases, the younger subjects found that the smaller rakes were still too difficult to accurately manipulate inside the boxes. These individuals often indicated a choice by attempting but failing to use the correct rake. Subjects were not penalised for a lack of physical strength,

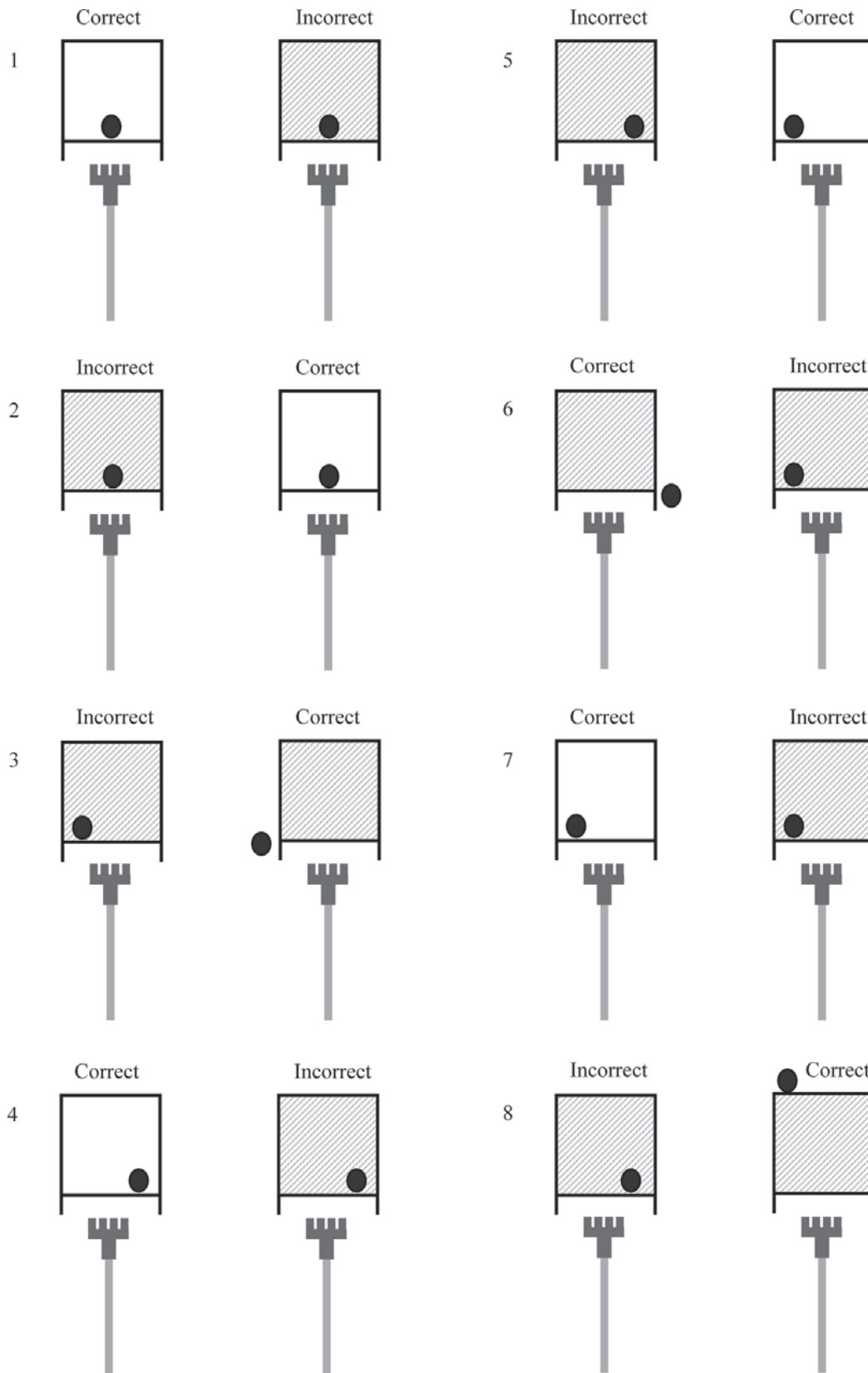

Fig. 9 Schematic representation of tool/reward choices viewed from subjects' perspective in experiment 3. The shaded boxes indicate conditions where a Perspex barrier prevented contact between the tool and the reward

and were rewarded for indicating the correct box, as this demonstrated an ability to discriminate whether the reward was accessible or not. An experimenter was present in the research room with each subject. A second experimenter was outside the room and was responsible for removing the rakes and setting up the apparatus between trials. Each trial was recorded on a video camera situated outside the room.

Results

Subjects chose the correct tool significantly more than would be expected by chance (median percentage correct = 75, median chance = 50; $Z = -2.97$, $n\text{-ties} = 11$, $P < 0.01$). Three subjects chose the correct box on every trial, with only three subjects choosing incorrectly on more than two trials. There was no evidence of a learning effect across the eight trials (Spearman's $P = 0.08$, $n = 8$, $P = 0.86$), nor was there a relationship between the age of the chimpanzees and their success (Spearman's $\rho = -1.36$, $n = 12$, $P = 0.67$).

Discussion of experiment 3

The results of this experiment indicate that chimpanzees appreciated that the Perspex barrier would prevent access to the food reward and were able to select the correct box accordingly. Three subjects chose the correct box on every trial, suggesting that subjects may have come to the experiment with previous knowledge about the properties of the tool, and barriers. As with experiment 2, they were able to use this knowledge to form rules specific to the new task.

The combined results of experiments 2 and 3 suggest that in experiment 1, subjects were able to determine by observation that actions to the top of the clear box were irrelevant, because they recognised that the tool must contact the reward in order to bring about a salient result, and that contact was prevented by the physical barrier.

Experiment 4: a comparative study with children

The literature suggests that pre-school children readily imitate observed actions (Want and Harris 2002). Children between the ages of 2 and 4 years old tend to employ imitation to solve tasks where chimpanzees have been found to emulate (Nagell et al. 1993; Whiten et al. 1996). Indeed, there is little evidence to date that children under the age of 4 years old use emulation (Want and Harris 2002). Imitation is thought to play an important role in children's language acquisition (Meltzoff 1988) and object knowledge (Abravanel and Gingold 1985; Barr et al. 1996; Meltzoff 1988), and is therefore an important learning mechanism throughout their development. It has been suggested that imitation may be such an adaptive strategy in young children that it is often employed in situations where alternative mechanisms would be more efficient (Whiten et al. 1996).

The literature also suggests that children of this age have knowledge of causal principles, including force and gravity, which they can combine to correctly predict the outcome of actions (Bullock et al. 1982; Shultz et al. 1982; for a review see Goswami 1998). Comparative studies have suggested that children may have a more theory-based understanding of causality than chimpanzees because they seem to seek causal explanations for observed effects (Tomasello 1998; Povinelli 2000; Povinelli and Dunphy-Lelii 2001). The following experiment was conducted to assess whether, when tested under conditions as similar as possible to the previous chimpanzee studies, children would use their knowledge of causality to switch between imitation and emulation to solve the same task.

Participants

Participants were 16 children: 8 female, 8 male (mean age: 4 years 1 month, range 41–59 months). The participants were African, Asian and Caucasian children recruited from St. Andrews University Day Nursery, St. Andrews, UK and Menzieshill Nursery School, Dundee, UK, once parental consent had been obtained. Children of this age were selected because the majority of chimpanzee subjects were of this age, and a recent criticism of the comparative literature has been that young humans are often compared to sub-adult or adult apes (Call et al. 2004). In addition, previous studies have indicated that this age group can provide informative comparative data in relation to social learning (Whiten et al. 1996; Whiten 2002).

Apparatus

The boxes used in this experiment were identical to those used in experiment 1. However, certain features were modified to make the task more suitable for children: (1) the reward was a Velcro-backed cartoon sticker, and (2) the end of the tool was accordingly covered in Velcro.

Procedure

The experiment was conducted as far as possible following the same procedures as experiment 1. The experimenter spent time at the playgroup prior to the investigation, so that the children would feel comfortable participating in the study. Children were tested individually in a separate room from the rest of the class. The apparatus was set up on a small table, and each child sat at the table on a chair beside the experimenter. Children and chimpanzees therefore observed the demonstrations from the same perspective.

During a pilot study with a different group of children, the children told the experimenter that they believed the game to be about copying the demonstrations, and were eager to show her how well they could copy what she did. It was felt that the presence of the demonstrator was influencing the children's perception of the task, and

hence two important differences in the procedure were introduced. Firstly, during each trial, the experimenter left the room while the child interacted with the apparatus. This was thought to be the most effective way to reduce any tendency to copy the experimenter through social conforming.¹ Secondly, the children were given limited verbal instruction. They were simply told that they could do whatever they thought necessary to get the sticker, and that the experimenter would be outside the room and could not see what they did. When they had successfully retrieved the reward they were told to shout “I have got it!” At this point the experimenter would return and give them their reward.

A video camera was set up at the back of the room behind toys and chairs so that it could not be easily seen. The camera started recording before each child entered the room, and continued to record throughout the experiment. At no point was the child’s attention drawn to the camera, and there was no reason to believe that the children knew that their actions were being recorded. Indeed, after retrieving the reward, children typically replaced the bolt and door defences to their original position before calling to the experimenter, thereby masking any visible evidence of their actions. The children were allocated to the same four groups used in experiment 1, with four individuals in each (male 3 years, female 3 years, male 4 years, female 4 years). For ethical reasons the names of the participants have been omitted.

Results

Experimental groups

There was no significant difference in the proportion of irrelevant actions performed by children from groups A and B (median A=77.5, median B=72.92; $Z=-2.08$, $n_1=4$, $n_2=4$, $P=0.06$), or between groups C and D (median C=78.33, median D=77.5; $Z=-0.3$, $n_1=4$, $n_2=4$, $P=0.87$). Two collapsed groups, A/B (opaque > clear) and C/D (clear > opaque) have therefore been used for the following analysis.

The reproduction of irrelevant actions was not influenced by age (median A/B 3 year olds =75, 4 year olds =74.17; $Z=-0.6$, $n_1=4$, $n_2=4$, $P=0.69$; median C/D 3 year olds = 78.33, 4 year olds = 77.5; $Z=-0.15$, $n_1=4$, $n_2=4$, $P=0.39$). Nor was performance influenced by sex (median A/B female =75, male =76.25; $Z=-0.74$, $n_1=4$, $n_2=4$, $P=0.49$; median C/D female =80, male =75; $Z=-2.08$, $n_1=4$, $n_2=4$, $P=0.6$).

Reproduction of relevant and irrelevant actions

There was no significant difference in the reproduction of irrelevant actions by children from group A/B in the opaque

¹ The pilot study also indicated that children tended to imitate regardless of whether (1) the experimenter was present or absent in the room, (2) a glove puppet was used as the model, (3) they were given no verbal instructions at all, or (4) they were given limited verbal instruction.

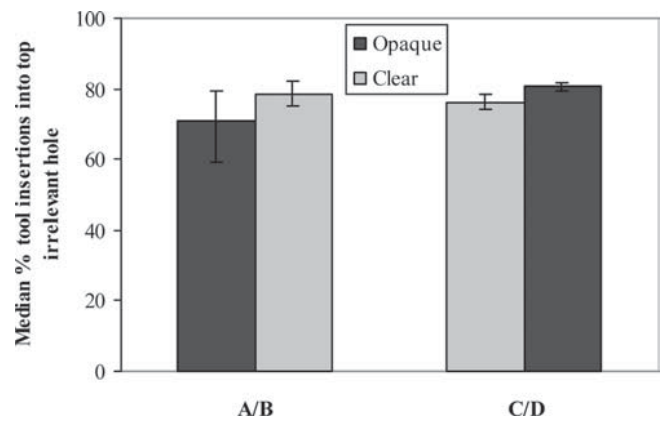

Fig. 10 The median percentage of tool insertions into the top, irrelevant hole by subjects from groups A/B and C/D in both the opaque and clear conditions. *Error bars* represent the inter-quartile range

and clear conditions (median A/B opaque =70.84, median A/B clear =80; $Z=-1.53$, n -ties =7, $P=0.13$; see Fig. 10). Therefore the opaque or clear appearance of the apparatus (and hence the availability of causal information), did not affect the children’s behaviour.

There was no significant difference in the reproduction of irrelevant actions by children from group C/D with the clear box, when compared to group A/B in either condition ($\chi^2=4.8$, $df=2$, $P=0.09$; see Fig. 10). Therefore, children from group A/B did not alter their behaviour between experimental conditions, and this was not influenced by previous experience with the opaque apparatus. When children from group C/D then transferred to the opaque apparatus there was no significant change in their behaviour (median C/D clear =75, median C/D opaque =80; $Z=-1.83$, n -ties =4, $P=0.07$). Therefore, like group A/B, the opaque or clear appearance of the apparatus, and hence the availability of causal information, did not effect the children’s behaviour.

Reproduction of two-action method of bolt removal

Children from groups A and C (A/C), who observed method 1 (push bolt), employed this technique significantly more than children from groups B and D (B/D) who observed method 2 (median A/C=100, median B/D=0; $Z=-3.57$, $n_1=8$, $n_2=8$, $P<0.001$; see Fig. 11). Similarly, children from group B/D who observed method 2, employed this technique significantly more than subjects in group A/C who saw method 1 (median B/D=91.66, median A/C=0; $Z=-3.57$, $n_1=8$, $n_2=8$, $P<0.001$).

Reproduction of two-action door removal

Children from group A/C, who observed method 1 (lift door), employed this technique significantly more than children from group B/D who observed method 2 (median A/C=100, median B/D=0; $Z=-3.57$, $n_1=8$, $n_2=8$, $P<0.001$). Similarly, children from group B/D who observed method 2, employed this technique significantly

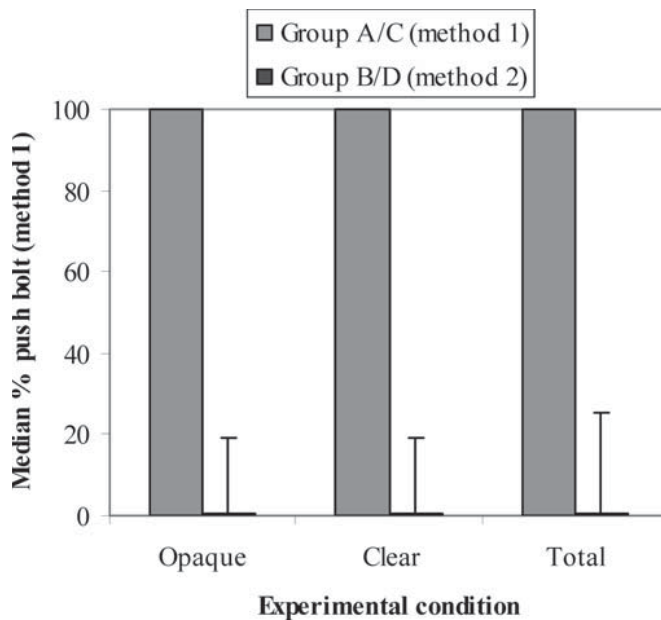

Fig. 11 Median percentage of method 1 (push bolt), used by subjects from groups A and C who observed method 1, and groups B and D who observed method 2

more than subjects in group A/C who saw method 1 (median B/D=91.66, median A/C=0; $Z=-3.57$, $n_1=8$, $n_2=8$, $P<0.001$). Children therefore used the observed method of both bolt and door removal significantly more than the alternative.

Discussion of experiment 4

The results of this experiment indicate that 3-year-old and 4-year-old children reproduced both the irrelevant and relevant actions, irrespective of whether the apparatus was opaque or clear, or the order in which the apparatus was presented (see Fig. 9). This suggests that the availability of causal information did not influence the social learning strategy that children employed. The inclusion of functionally irrelevant actions, coupled with the high fidelity reproduction of the observed two-action methods of both bolt and door defence removal (see Fig. 10), suggest that children relied strongly on imitation to retrieve the reward in both conditions. The tendency to imitate was not influenced by either the age or the sex of the children.

General discussion

Causal information and chimpanzee social learning

Experiment 1 suggests that chimpanzees who interacted first with the opaque box, in which causal information was unavailable, typically used imitation to retrieve the reward: that is to say, chimpanzees performed a more complete copy of the overall structure of model's behaviour (Byrne and Russon 1998) that included the irrelevant parts of the

demonstration. These subjects switched to a more emulative approach when presented with the clear apparatus, insofar as they reproduced the results of the model, but did not copy the irrelevant parts of the observed behaviour. Chimpanzees who interacted with the clear apparatus first also used emulation to retrieve the reward, and continued to do so when presented with the opaque apparatus, although the opportunity to monitor the effect of the tool inside the apparatus had been removed. This suggests that they may have been able to generalise the information gained through experience with the clear box to the new experimental condition.

The results of experiments 2 and 3 are consistent with our interpretation of experiment 1 that chimpanzees were able to determine that actions to the top of the box were irrelevant, because they recognised that the tool must make contact with the reward in order to produce a salient effect, and that contact was prevented by the barrier. These studies do not provide evidence about the source of this knowledge. However, even if this knowledge were restricted to the formation of general rules about the necessity for contact, it would not diminish the potentially important role of causal information in chimpanzee social learning. Appreciating that the tool must make some relevant contact with a reward is all that is required to differentiate the relevant and irrelevant aspects of the observed demonstration in experiment 1.

Therefore, the notion that commonly arises in the literature, which suggests that the predominant use of emulation by chimpanzees indicates a deficit of imitation, may be misleading. The results of this paper suggest more generally that when chimpanzees have access to causal information, they may use this information to develop the most efficient technique, in accord with emulation. Furthermore, they may be able to generalise their existing causal knowledge to new situations. However, when causal information is restricted, and they are prevented from using alternative, more flexible forms of social learning, they can employ imitation to solve all, or part of a problem. Therefore we suggest that causal information may play an important role in chimpanzee social learning by allowing individuals to identify the relevant aspects of a demonstration, which determines the strategy that is employed, and ultimately the degree of behavioural fidelity that is achieved. A related finding in a recent study by Call et al. (2004) showed that chimpanzees who observed a demonstrator try but fail to retrieve a reward using one of two alternative methods were able to selectively ignore the unsuccessful method in favour of the alternative, potentially successful technique, thus utilising the available causal information.

One of the recent criticisms of the concept of emulation in the literature is that it has been seen as a null hypothesis (Byrne 2002). Emulation is often claimed when apes show no evidence of imitation, but seem to learn more than would be expected through enhancement. Hence, emulation has not been empirically demonstrated in its own right (Byrne 2002). We suggest that the current study offers empirical evidence for the existence of emulation as a viable social learning strategy in chimpanzees, and that the occurrence

of emulation can be determined by the use of information about causal relationships.

The ability of chimpanzees to switch from a strategy of imitation to emulation contrasts with an earlier finding by Call and Tomasello (1995). Orangutans observed both a human and conspecific demonstrator perform a number of actions to retrieve a food reward from an opaque box. As with the opaque box in the present study, the effect of these actions on the reward could not be perceived. However, it was found that subjects failed to solve this task. Since emulation could not be used to retrieve the reward, and imitation was the only viable strategy, the failure of subjects to retrieve the reward was interpreted as a lack of imitative ability. However, the retrieval of the reward relied on the reproduction of movements of a lever that released and retrieved the reward. It is possible that the demonstrated movements were too small or too similar to be effectively differentiated or reproduced by apes. The actions required for the present study were likely clearer and easier to discriminate between and execute. We suspect this to be the most likely explanation, although we cannot rule out the potential influence of species differences between the two studies.

The issue of enculturation

Some authors have argued that extensive human contact can lead to a fundamental change in the socio-cognitive development of great apes, known as “enculturation” (Premack 1983; Call and Tomasello 1998a). It has been proposed that enculturation increases a broad base of socio-cognitive skills due to increased exposure to objects with specific functions, increased observation of human demonstrations, attention focusing through training and being treated as intentional individuals (Tomasello et al. 1993a,b; Call and Tomasello 1998a). Tomasello et al. (1993b) found that enculturated chimpanzees and human children could imitate novel object actions significantly more than mother-raised chimpanzees, and it has been suggested that only enculturated apes are capable of imitation (Nagell et al. 1993; Call and Tomasello 1995; Bering et al. 2000; Bjorklund et al. 2000, 2002). Although the enculturation hypothesis has been disputed by some (see Boesch 1993; Whiten 1993; Bering 2004; Tomasello and Call 2004 for a rejoinder), it might be suspected that the rearing history of the chimpanzees in this study was species atypical, and that the results cannot be generalised to chimpanzees as a whole.

However, the chimpanzees of Ngamba island experienced very few “human” objects with specific functions. Any objects that were introduced acted as a form of enrichment and chimpanzees did not receive demonstrations or training about how the objects should be manipulated. The chimpanzees spent the majority of time in a peer group with daily excursions into the forest with adult female conspecifics, and were rarely one-on-one with humans outside the context of scientific study. Humans who did interact with the chimpanzees did so by using chimpanzee-typical gestures and vocalisations where possible. When in contact

with humans, the chimpanzees were treated as intentional individuals, but the influence of this interaction is thought to be less intense than would be experienced by a home-raised ape. We therefore do not believe that subjects can be considered as enculturated in the same sense as some studied by other researchers (Tomasello et al. 1993b; Bering et al. 2000; Bjorklund et al. 2000, 2002). Instead, the stimulation that is received on Ngamba island can be viewed as a replacement for the rich social and physical environment that would be experienced in the wild (Whiten 1993), and to this extent the results of this study are likely to have implications for chimpanzee cognition in general. For example, it would be expected that in wild populations, learning behaviours such as termite-fishing, where certain effects of the tool cannot be seen, may call upon different social learning strategies than behaviours such as nut-cracking, where the effect of the tool can be constantly monitored.

Chimpanzees and children compared

In contrast to the chimpanzees, children tended to recreate the actions they observed without appearing to consider the causal efficiency of their behaviour. Yet the literature, as noted earlier, suggests that children of this age have appropriate causal knowledge. Why then did the children, unlike the chimpanzees, not utilise this knowledge to develop the most efficient technique to retrieve the reward?

A first possibility is that children’s knowledge of causality is unavailable to other cognitive functions such as social learning. However, a number of studies have found that children could selectively ignore irrelevant actions in an observed sequence (Harnick 1978; Want and Harris 2001; Bauer and Kleinknecht 2002). Similarly, Bullock et al. (1982) found that 3- to 5-year-old children could correctly predict which physical changes to a piece of apparatus were functionally relevant or irrelevant. It is therefore unlikely that the failure of children to differentiate between the irrelevant and relevant actions in the present study was the result of limitations in their causal knowledge.

A second possibility is that the children’s tendency to imitate was related to the difficulty of the task. It has been shown that irrelevant actions are more likely to be ignored as the difficulty of a task decreases (Harnick 1978; Bauer and Kleinknecht 2002). However, pilot work indicated that children continued to reproduce both irrelevant and relevant actions when the defences of the box were removed, thereby making the task simpler. Hence, we think it unlikely that children’s homogenous behaviour was a function of task difficulty.

Thirdly, the difference in performance of chimpanzees and children may result from a differential focus of attention. Imitation may predominate in children because they attend more to the actions of others than the results of their behaviour (Bellagamba and Tomasello 1999; Bekkering et al. 2000). Call and Carpenter (2002) have suggested that in contrast, chimpanzees attend preferentially to goals and results, and this may account for the observed tendency of

chimpanzees and children to use different social learning strategies.

Finally, it is possible that the divergent results for children and chimpanzees are due to differences in inferring “intention”. Although few studies have been carried out, there is conflicting evidence about whether chimpanzees are able to interpret actions in the framework of intentions (Call and Tomasello 1998b; Povinelli et al. 1998; Bering 2004; Tomasello and Call 2004). The developmental literature indicates that children can differentiate between intended and accidental actions, and can use this information to complete intended but failed demonstrations (Bellagamba and Tomasello 1999; Carpenter et al. 1998; Meltzoff 1995). However, alternative explanations are possible (Charman and Huang 2002; Heyes and Ray 2002), and care must be taken since all intentions must be “inferred” (Zentall 2001), even in our own species (Horowitz 2003). Nevertheless, it remains a possibility that in the present study children, but not chimpanzees, reproduced the irrelevant actions of the demonstrator in all conditions because they were more inclined to view the actions of the demonstrator as intentional. Indeed, Gergely et al. (2002) have shown that children will imitate strange behaviours, such as using one’s head to work a switch, as long as they view the actions of the demonstrator as purposeful.

The children’s reproduction of irrelevant actions in this study contrasts with the findings of Want and Harris (2001), who found that 3-year-old children could benefit from, but selectively exclude, irrelevant actions from an observed sequence. However, in the Want and Harris study, the accidental irrelevant actions were followed by the demonstrator saying “Oops”. Subjects also received only one demonstration before they were given an opportunity to interact with the apparatus. Children may have reproduced the irrelevant actions in the present study because the demonstration was repeated three times before subjects could interact with the apparatus (increasing the probability that the actions were purposeful), and the demonstrator did not verbally identify the irrelevant actions as either accidental or undesirable. Children may therefore have included all the observed actions because they saw the behaviour of the demonstrator as intentional, even if they did appreciate that some parts of the demonstration were causally irrelevant. We therefore believe that differences in the behaviour of chimpanzees and children can best be explained by a combination of a differential focus of attention on actions, results and goals, with the latter possibly influencing the interpretation of the actions of the demonstrator as purposeful.

Conclusions

The results of this series of experiments suggest that the availability of causal information can play an important role in chimpanzee social learning, by determining which learning strategy is employed, and ultimately the degree of behavioural fidelity that is achieved. When causal information was available, young chimpanzees preferred to use emulation to solve a task. This may be adaptive because learn-

ing about the causal relationships involved in a task allows socially learned behaviours to be generalised to different conditions (Tomasello et al. 1987; Visalberghi 1994; Want and Harris 2001, 2002). However, if causal information was unavailable or difficult to infer, young chimpanzees were capable of switching to imitation to solve all, or part of the task. In contrast, in the context of this study, 3- to 4-year-old children did not seem to consider the causal relevance of their behaviour, and imitation was the preferred social learning strategy regardless of the availability of causal information. The prevalence of imitation in children may result from a predominant focus on the actions and/or intentions of the demonstrator. The results of this paper are in accord with other studies that have shown children to employ imitation in situations where alternative social learning strategies may be more efficient (Nagell et al. 1993; Whiten et al. 1996). It has been suggested that imitation may be such an adaptive human strategy that it is often employed at the expense of efficiency (Whiten et al. 1996). It may also be that emulation is such an adaptive strategy in chimpanzees that it is often employed at the expense of copying fidelity.

Acknowledgements This research was supported by a studentship from the Biotechnology and Biological Sciences Research Council, UK. We are exceedingly grateful to Debby Cox, Monty Montgomery, and the trustees and staff of Ngamba Island for their help and support. Chimpanzee research was in compliance with the Uganda National Council for Science and Technology, whom we also thank. Thanks to Pauline Osborne and Ora McNaught who played the role of the second experimenter, and Carla Litchfield for coding tapes. We are grateful to the staff and pupils of Menzieshill Nursery School and St. Andrews University Day Nursery. V.H. would like to thank Michael Niebuhr for support during data collection and, along with Victoria Southgate and the four referees for helpful comments during the preparation of this manuscript.

References

- Abravanel E, Gingold H (1985) Learning via observation during the second year of life. *Dev Psychol* 21:614–623
- Barr R, Dowden A, Hayne H (1996) Developmental changes in deferred imitation by 6- to 24-month-old infants. *Infant Behav Dev* 19:159–170
- Bauer PJ, Kleinknecht EE (2002) The ‘ape’ or to emulate? Young children’s use of both strategies in a single study. *Dev Sci* 5:18–20
- Bekkering H, Wohlschlagel A, Gattis M (2000) Imitation of gestures in children is goal-directed. *Q J Exp Psychol* 53A:153–164
- Bellagamba F, Tomasello M (1999) Re-enacting intended acts: comparing 12- and 18-month-olds. *Infant Behav Dev* 22:277–282
- Bering JM (2004) A critical review of the enculturation hypothesis: the effects of human rearing on great ape social cognition. *Anim Cogn*. DOI:10007/s10071-004-0210-6
- Bering JM, Bjorklund DF, Regan P (2000) Deferred imitation of object-related actions in human-reared juvenile chimpanzees and orangutans. *Dev Psychobiol* 36:218–232
- Bjorklund DF, Bering JM, Regan P (2000) A two-year longitudinal study of deferred imitation of object manipulation in a juvenile chimpanzee (*Pan troglodytes*) and orangutan (*Pongo pygmaeus*). *Dev Psychobiol* 37:229–237
- Bjorklund DF, Yunger JL, Bering JM, Regan P (2002) The generalisation of deferred imitation in enculturated chimpanzees (*Pan troglodytes*). *Anim Cogn* 5:49–58

- Boesch C (1993) Transmission of tool-use in wild chimpanzees. In: Gibson KR, Ingold T (eds) Tools, language and cognition in human evolution. Cambridge University Press, Cambridge, pp 171–183
- Boesch C, Boesch H (1990) Tool use and tool making in wild chimpanzees. *Folia Primatol* 54:86–99
- Boesch C, Tomasello M (1998) Chimpanzee and human cultures. *Curr Anthropol* 39:591–614
- Brewer SM, McGrew WC (1990) Chimpanzee use of a tool-set to get honey. *Folia Primatol* 54:100–104
- Bullock M, Gelman R, Baillargeon R (1982) The development of causal reasoning. In: Friedman WJ (ed) The developmental psychology of time. Academic, New York, pp 209–254
- Byrne RW (1998) Commentary on Boesch, C. and Tomasello, M. chimpanzee and human culture. *Curr Anthropol* 39:604–605
- Byrne RW (2002) Emulation in apes: verdict ‘not proven’. *Dev Sci* 5:20–22
- Byrne RW, Russon AE (1998) Learning by imitation: a hierarchical approach. *Behav Brain Sci* 21:667–721
- Call J, Carpenter M (2002) Three sources of information in social learning. In: Dautenham K, Nehaniv C (eds) Imitation in animals and artifacts. MIT Press, Cambridge, Mass., pp 211–228
- Call J, Tomasello M (1994) The social learning of tool use by orangutans. *Hum Evol* 9:297–313
- Call J, Tomasello M (1995) Use of social information in the problem solving of Orangutans (*Pongo pygmaeus*) and human children (*Homo sapiens*). *J Comp Psychol* 109:308–320
- Call J, Tomasello M (1998a) The effect of humans on the cognitive development of apes. In: Russon AE, Bard KA, Parker ST (eds) Reaching into thought: the minds of the great apes. Cambridge University Press, Cambridge, pp 371–403
- Call J, Tomasello M (1998b) Distinguishing intentional from accidental actions in orangutans (*Pongo pygmaeus*), chimpanzees (*Pan troglodytes*) and human children (*Homo sapiens*). *J Comp Psychol* 112:192–206
- Call J, Carpenter M, Tomasello M (2004) Copying results and copying actions in the process of social learning: chimpanzees (*Pan troglodytes*) and human children (*Homo sapiens*). *Anim Cogn* (in press)
- Carpenter M, Akhtar N, Tomasello M (1998) Fourteen- through 18-month-old infants differentially imitate intentional and accidental actions. *Infant Behav Dev* 21:315–330
- Charman T, Huang C (2002) Delineating the role of stimulus enhancement and emulation learning in the behavioural re-enactment paradigm. *Dev Sci* 5:25–27
- Custance DM, Whiten A, Bard KA (1995) Can young chimpanzees (*Pan troglodytes*) imitate arbitrary actions? Heyes and Heyes (1952) revisited. *Behaviour* 132:837–838
- Custance D, Whiten A, Fredman T (1999) Social learning of an artificial fruit task in Capuchin monkeys (*Cebus apella*). *J Comp Psychol* 113:13–23
- Dawson BV, Foss BM (1965) Observational learning in budgerigars. *Anim Behav* 13:470–474
- Galef BG (1992) The question of animal culture. *Hum Nat* 3:157–178
- Gergely G, Bekkering H, Kiraly I (2002) Rational imitation in preverbal infants. *Nature* 415:755
- Goodall J (1986) The chimpanzees of Gombe: patterns of behaviour. Harvard University Press, Cambridge
- Goswami U (1998) Cognition in children. Psychology Press, Hove, UK
- Harnick FS (1978) The relationship between ability level and task difficulty in producing imitation in infants. *Child Dev* 49:209–212
- Heyes CM (1993) Imitation, culture and cognition. *Anim Behav* 46:999–1010
- Heyes CM, Ray ED (2002) Distinguishing intention-sensitive from outcome-sensitive imitation. *Dev Sci* 5:34–36
- Horowitz AC (2003) Do humans ape? or do apes human? Imitation and intention in humans (*Homo sapiens*) and other animals. *J Comp Psychol* 117:325–336
- Köhler W (1927) The mentality of apes. Vintage, New York
- Limongelli L, Boysen ST, Visalberghi E (1995) Comprehension of cause–effect relations in a tool-using task by chimpanzees (*Pan troglodytes*). *J Comp Psychol* 109:18–26
- Meltzoff AN (1988) Imitation, objects, tools and the rudiments of language in human ontogeny. *Hum Evol* 3:45–64
- Meltzoff AN (1995) Understanding the intentions of others: re-enactment of intended acts by 18-month-old children. *Dev Psychol* 31:1–16
- Myowa-Yamakoshi M, Matsuzawa T (2000) Imitation of intentional manipulatory actions in chimpanzees (*Pan troglodytes*). *J Comp Psychol* 114:381–391
- Nagell K, Olgin RS, Tomasello M (1993) Processes of social learning in the tool use of chimpanzees (*Pan troglodytes*) and human children (*Homo sapiens*). *J Comp Psychol* 107:174–186
- Povinelli DJ (2000) Folk physics for apes: a chimpanzee’s theory of how the world works. Oxford University Press, Oxford
- Povinelli DJ, Dunphy-Lelii S (2001) Do chimpanzees seek causal explanations? Preliminary comparative investigations. *Can J Exp Psychol* 55:185–193
- Povinelli DJ, Perilloux HK, Reaux JE, Bierschwale DT (1998) Young and juvenile chimpanzees’ (*Pan troglodytes*) reaction to intentional versus accidental and inadvertent actions. *Behav Process* 42:205–218
- Premack D (1983) The codes of man and beasts. *Behav Brain Sci* 6:125–167
- Reaux RE, Povinelli DJ (2000) The trap-tube problem. In: Povinelli DJ (ed) Folk physics for apes: a chimpanzee’s theory of how the world works. Oxford University Press, Oxford, pp 108–131
- Shultz TR, Pardo S, Altmann E (1982) Young children’s use of transitive inference in causal chains. *Br J Psychol* 73:235–241
- Sugiyama Y (1985) The brush-stick of chimpanzees found in South-west Cameroon and their cultural characteristics. *Primates* 26:361–374
- Sugiyama Y (1997) Social traditions and the use of tool-composites by wild chimpanzees. *Evol Anthropol* 6:23–27
- Sugiyama Y, Koman J (1979) Tool using and tool making behaviour in wild chimpanzees at Bossou, Guinea. *Primates* 20:513–524
- Suzuki S, Kuroda S, Nishihara T (1995) Tool-set for termite fishing by chimpanzees in the Ndoki forest, Congo. *Behaviour* 132:219–235
- Tomasello M (1990) Cultural transmission in the tool use and communicatory signalling of chimpanzees? In: Parker ST, Gibson KR (eds) Cultural transmission in the tool use and communicatory signalling of chimpanzees? Cambridge University Press, Cambridge, pp 247–273
- Tomasello M (1996) Do apes ape? In: Heyes CM, Galef BG (eds) Do apes ape? Academic, London, pp 319–346
- Tomasello M (1998) Emulation learning and cultural learning. *Behav Brain Sci* 21:703–704
- Tomasello M, Call J (2004) The role of humans in the cognitive development of apes revised. *Anim Cogn* (in press)
- Tomasello M, Davis-Dasilva M, Camak L, Bard K (1987) Observational learning of tool use by young chimpanzees and enculturated chimpanzees. *Hum Evol* 2:175–183
- Tomasello M, Kruger AC, Ratner HH (1993a) Cultural learning. *Behav Brain Sci* 16:495–552
- Tomasello M, Savage-Rumbaugh ES, Kruger A (1993b) Imitative learning of actions on objects by children, chimpanzees and enculturated chimpanzees. *Child Dev* 64:1688–1705
- Visalberghi E (1994) Capuchin monkeys: a window into tool use in apes and humans. In: Gibson KR, Ingold T (eds) Tools, language and cognition in human evolution. Cambridge University Press, Cambridge, pp 138–150
- Visalberghi E, Tomasello M (1998) Primate causal understanding in the physical and psychological domains. *Behav Process* 42:189–203
- Visalberghi E, Fragaszy DM, Savage-Rumbaugh S (1995) Performance in a tool-using task by common chimpanzees (*Pan troglodytes*), bonobos (*Pan paniscus*), an orangutan (*Pongo pygmaeus*), and capuchin monkeys (*Cebus apella*). *J Comp Psychol* 109(1):52–60

- Want SC, Harris PL (2001) Learning from other peoples' mistakes: causal understanding in learning to use a tool. *Child Dev* 72:431–443
- Want SC, Harris PL (2002) How do children ape? Applying concepts from the study of non-human primates to the developmental study of 'imitation' in children. *Dev Sci* 5:1–41
- Whiten A (1993) Human enculturation, chimpanzee enculturation and the nature of imitation. Commentary on cultural learning, by M. Tomasello. *Behav Brain Sci* 16:538–539
- Whiten A (1998) Imitation of the sequential structure of actions by chimpanzees (*Pan troglodytes*). *J Comp Psychol* 112:270–281
- Whiten A (2002) Imitation of sequential and hierarchical structure in action: experimental studies with children and chimpanzees. In: Dautenham K, Nehaniv C (eds) *Imitation in animals and artifacts*. MIT Press, Cambridge, pp 191–209
- Whiten A, Ham R (1992) On the nature and evolution of imitation in the animal kingdom: reappraisal of a century of research. In: Slater PJB, Rosenblatt JS, Beer C, Milinski M (eds) *On the nature and evolution of imitation in the animal kingdom: reappraisal of a century of research*. Academic, New York, pp 239–283
- Whiten A, Custance DM, Gomez J, Teixidor P, Bard KA (1996) Imitative learning of artificial fruit processing in children (*Homo sapiens*) and chimpanzees (*Pan troglodytes*). *J Comp Psychol* 110:3–14
- Zentall T (2001) Imitation in animals: evidence, function, and mechanism. *Cybern Syst* 32:53–96

Reproduced with permission of the copyright owner. Further reproduction prohibited without permission.